

## Handling Grapple

### M Series

For 3 to 60 m t carriers (6,600 to 132,000 lbs)



The design and clamping force of the handling grapple of Tramac make them the natural choice for sorting and moving demolished materials, rock, handling of various materials, urban waste, garbage and dramatically reduce loading times.

#### Many Advantages:

- Can be used with a complete range of carriers from 3 t to 60 t
- Compact, manageable, fast and versatile
- Continuous 360° hydraulic rotation enables the equipment to be used in all situations in order to improve production and prevent risk of injury to operators
- Complete structure made in Hardox 400 for improved durability
- High safety clamping force thanks to the block valve (except HGR-03), which keeps the grapple closed and prevents cylinder oil leaks
- Interchangeable blades

For dimensions and specifications, see back of this page.

Handling Grapple - M Series



# Hangling Grapple

## Specifications and Dimensions

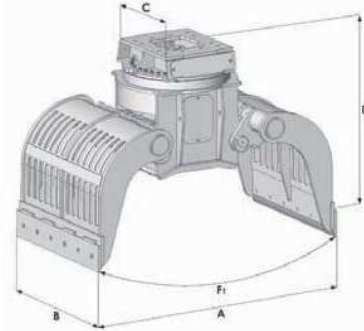

MODELE		HGR-03	HGR-05	HGR-10	HGR-15	HGR-18	HGR-22	HGR-25	HGR-30	HGR-41
A	mm po	1040 41	1500 59	1750 69	1850 73	1850 73	2070 82	2070 82	2200 87	2500 98
B	mm po	400 16	600 23.5	800 31.5	800 31.5	1000 39	1000 39	1200 47	1400 55	1500 59
C	mm po	510 20	640 25	640 25	830 32.5	830 32.5	895 35	895 35	1110 43.5	1110 43.5
D	mm po	830 32.5	1040 41	1270 50	1295 51	1278 50.3	1525 60	1525 60	1650 65	1850 73
Volume	l g	60 13.5	210 48	390 88.5	440 100	550 125	800 182	1000 227	1200 272	1600 363
F1	t m t us	2 2.2	3 3.3	4 4.4	5 5.5	6 6.6	7 7.7	8 8.8	10 11	14 15.4
Rotation Flow	lpm gpm	10 2.6	10 2.6	30 8	30 8	30 8	50 13	50 13	50 13	50 13
Rotation Pressure	bar psi	200 2900	200 2900	200 2900	200 2900	200 2900	200 2900	200 2900	120 1740	120 1740
Open/Close Flow	lpm gpm	20 5	25 6.5	40 10.5	40 10.5	40 10.5	60 16	60 16	90 23.8	120 31.7
Open/Close Pressure	bar psi	200 2900	320 4640	320 4640	320 4640	320 4640	320 4640	320 4640	320 4640	320 4640
Rotation	°	360°	360°	360°	360°	360°	360°	360°	360°	360°
Weight	kg lbs	280 617	548 1208	880 1940	1055 2325	1200 2645	1703 3755	1855 4090	2456 5415	3640 8025
Excavator Weight	t m t us	3/5 3.3/5.5	5/10 5.5/11	10/15 11/16.5	15/20 16.5/22	16/22 17.6/24	22/30 24/33	25/35 27.5/38.5	30/40 33/44	40/60 44/66

### Quality and dependability: two features you can count on with every TRAMAC product.

All TRAMAC products are engineered for superior performance, manufactured to the most exacting specifications, and—within the guidelines of the industry's most rigid quality control program—thoroughly inspected at every stage of production. All working parts are precision-machined to the closest tolerances, and all materials meet or exceed the highest industry standards. These are but a few of the many vital reasons major contractors worldwide choose our products.

