

Rockbreaker Booms

TX Series

for breakers up to 8000 ft. lb. class.



TX Series Rockbreaker Booms

ALL NEW, EXTRA HEAVY-DUTY boom assemblies for large breakers at demanding, high-production work locations.

DESIGNED FOR THE BIGGEST JOBS: Tramac's all new TX Series Stationary Rock Breakers are extremely heavy-duty assemblies. The series is designed to carry breakers weighing up to 5555 lbs., energy classes to 8000 ft lbs., and is ideally suited for work serving large crushers in gyratory dump pockets, over grizzlies, underground ore passes and other high production locations where large breakers are required. These designs are the beneficiaries of many years' experience in providing rock breaking equipment to demanding mineral mines and crushed stone producers worldwide. The TX incorporates an extra large pedestal base with large diameter kingpins and swing post. Its heavy duty tubular steel construction is reinforced in critical areas.

CYLINDERS: Heavy duty cylinders are of welded construction with spherical bearings in both ends. The boom and dipperstick cylinders include cushioning and load drop counter balance valves.

ADVANCED CONTROLS: These systems are equipped with the very latest electro-hydraulic joystick operated controls. Each function is supplied a precisely metered amount of hydraulic power, with reliefs set to instantly protect from dangers that can arise when working in conjunction with other moving equipment. Radio controlled joystick systems, in lieu of a standard tethered joystick box or in addition to it, are one of today's frequently requested accessories.

POWER UNITS: We produce a full range of hydraulic power units to match all hammer and boom combinations. Our units use an integrated tank and stand design with an elevated reservoir providing a flooded pump inlet. The heart of each unit is an electric motor mated to a multi-sectioned fixed displacement gear pump. These motors will be supplied with local voltage specs as site required. Units can be equipped with accessories as necessary. Standard units include low level and high temperature shut down switch and circuitry.

PROPER SET-UP: The key to long equipment life and top production is to start with the boom placed in exactly the right spot. When working in your target area, a boom is positioned in its "sweet spot" when it is arched symmetrically and the cylinders are in their mid positions. Tramac engineers will gladly work with you to find the right boom base position so you can reach the areas of top priority.

INCREASED SAFETY AND PRODUCTION: Increase safety around your primary. Eliminate the need for a worker to enter the area. Increase your up-time. Provide a steady flow of materials. Break rock, pull, poke and stir material. Reach into the crusher with smooth precision of control.

For dimensions and specifications, see reverse side.

TX Booms: Approximate Working Ranges

Boom Breaker		TX52						TX62					
		900	V32	V1200	V1800	V46	V2500	900	V32	V1200	V1800	V46	V2500
A	ft-in	17'2"	17'2"	17'2"	17'2"	17'2"	17'2"	21'1"	21'1"	21'1"	21'1"	21'1"	21'1"
	mm	5236	5236	5236	5236	5236	5236	6423	6423	6423	6423	6423	6423
B	ft-in	11'10"	11'10"	11'10"	11'10"	11'10"	11'10"	14'6"	14'6"	14'6"	14'6"	14'6"	14'6"
	mm	3607	3607	3607	3607	3607	3607	4420	4420	4420	4420	4420	4420
C	ft-in	4'1"	3'5"	2'9"	2'8"	2'3"	1'8"	7'1"	6'5"	5'9"	5'10"	5'3"	4'8"
	mm	1245	1041	838	813	686	508	2159	1956	1753	1778	1600	1422
D	ft-in	8'7"	8'7"	8'7"	8'7"	8'7"	8'7"	10'0"	10'0"	10'0"	10'0"	10'0"	10'0"
	mm	2616	2616	2616	2616	2616	2616	3048	3048	3048	3048	3048	3048
E	ft-in	14'7"	15'3"	15'11"	16'0"	16'5"	17'0"	17'6"	18'2"	18'10"	18'11"	19'4"	19'11"
	mm	4445	4648	4851	4877	5004	5182	5334	5537	5740	5766	5893	6071
F	ft-in	23'11"	24'7"	25'3"	25'4"	25'9"	25'4"	27'11"	28'7"	29'3"	29'2"	29'9"	30'3"
	mm	7299	7493	7696	7722	7849	8026	8509	8712	8915	8890	9068	9220
G	ft-in	13'10"	13'10"	13'10"	13'10"	13'10"	13'10"	15'6"	15'6"	15'6"	15'6"	15'6"	15'6"
	mm	4216	4216	4216	4216	4216	4216	4775	4775	4775	4775	4775	4775

TX Booms: Approximate Working Ranges

Boom Breaker		TX72						TX82					
		900	V32	V1200	V1800	V46	V2500	900	V32	V1200	V1800	V46	V2500
A	ft-in	24'5"	24'5"	24'5"	24'5"	24'5"	24'5"	28'0"	28'0"	28'0"	28'0"	28'0"	28'0"
	mm	7442	7442	7442	7442	7442	7442	8534	8534	8534	8534	8534	8534
B	ft-in	16'10"	16'10"	16'10"	16'10"	16'10"	16'10"	19'3"	19'3"	19'3"	19'3"	19'3"	19'3"
	mm	5131	5131	5131	5131	5131	5131	5893	5893	5893	5893	5893	5893
C	ft-in	8'9"	8'1"	7'5"	7'4"	6'11"	6'4"	10'9"	10'1"	9'5"	9'4"	8'11"	8'4"
	mm	2718	2464	2261	2235	2108	1930	3277	3073	2870	2845	2718	2540
D	ft-in	10'11"	10'11"	10'11"	10'11"	10'11"	10'11"	11'11"	11'11"	11'11"	11'11"	11'11"	11'11"
	mm	3327	3327	3327	3327	3327	3327	3632	3632	3632	3632	3632	3632
E	ft-in	20'1"	20'9"	21'5"	21'6"	21'11"	22'6"	22'7"	23'3"	23'11"	24'0"	24'5"	25'0"
	mm	6121	6325	6528	6553	6680	6858	6883	7087	7290	7315	7442	7620
F	ft-in	31'3"	31'11"	32'7"	32'8"	33'1"	33'8"	34'9"	35'5"	36'1"	36'2"	36'7"	37'2"
	mm	9525	9728	9931	9957	10084	10262	10592	10795	11000	11024	11151	11328
G	ft-in	17'1"	17'1"	17'1"	17'1"	17'1"	17'1"	18'11"	18'11"	18'11"	18'11"	18'11"	18'11"
	mm	5207	5207	5207	5207	5207	5207	5766	5766	5766	5766	5766	5766

TX Booms Specifications

Model		TX52	TX62	TX72	TX82
Nominal Horizontal Reach	ft	17'	21'	24'	28'
	m	5.2	6.4	7.3	8.5
Swing Arc	°	160	160	160	160
Weight (excluding breaker and power pack)	lbs	13950	14750	15650	16300
	kg	6330	6700	7100	7400
Breaker Impact Class Range	ft-lbs	3000-8000	3000-8000	3000-8000	3000-8000

Breaker Model		900	V32	V1200	V1800	V46	V2500
Energy Class	ft-lbs	3000	5000	5000	6000	7500	8000
Operating Weight	lbs	2540	3320	3740	3915	5615	5555
	kg	1151	1506	1696	1775	2547	2520
Flow Range	GPM	26-40	32-45	32-45	37-58	48-70	46-66
	l/min	100-150	120-170	120-170	140-220	180-265	175-250
Max. Working Pressure	PSI	1813	1950	2250	2393	2400	2250
	Bar	125	135	155	165	165	155
Frequency Range	BPM	400-800	285-1050	370-770	310-500	510-1160	350-500
Tool Diameter	in	4.65	4.8	4.8	5.5	6	6.3
	mm	118	122	122	140	150	160

Dealer:

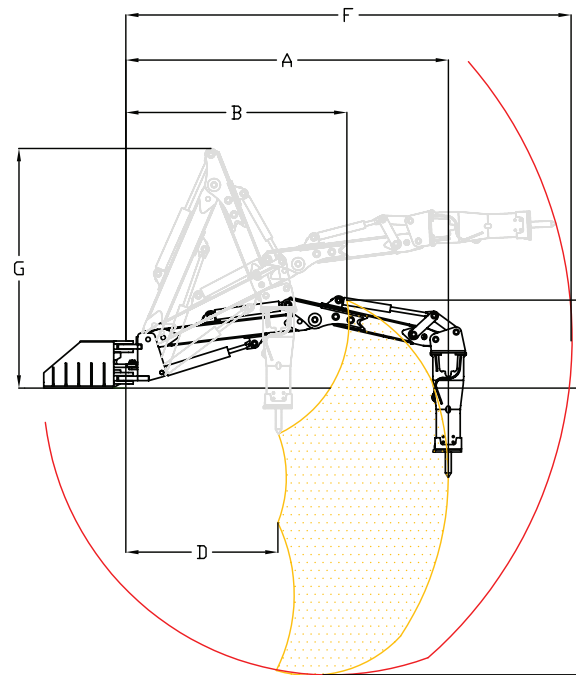

USA: 12 Orben Drive, #3, Landing, NJ 07850 / 1-800-526-3837 / 1-973-770-4457 / FAX 1-973-770-0812
Canada: 3421 boul. Industriel / Laval, QC / Canada H7L 4S3 / 1-888-663-8122 / 1-450-663-8122 / FAX 1-450-663-6797
 e-mail: sales@tramac.com http://www.tramac.com

